

MODEL

TP



INSTALLATION, OPERATION & MAINTENANCE MANUAL

TP Sampling valve (Ø25/40)



MODEL

TP



INSTALLATION, OPERATION & MAINTENANCE MANUAL

TP Sampling valve (Ø25/40)

0. INTRODUCTION

1. INSTALLATION

2. ACTUATORS

2.1. Lever

2.2. Pneumatic

3. MAINTENANCE

3.2. Seal replacement

4. STORAGE

5. ENVIRONMENTAL CONSIDERATIONS

6. PARTS LIST & DRAWING

6.1. Lever actuator

6.2. Pneumatic actuator

0. INTRODUCTION

The TP valve is designed to get fluid samples from a pipeline or a tank.

1. INSTALLATION



In order to avoid personal injury or damage to property when handling and installing the valve, it is important to observe the following warnings:

- It is the User's responsibility to verify compatibility of valve parts materials with the internal fluid
- Qualified and trained personnel must carry out the handling and maintenance of the valve
- Use suitable Individual Protection Equipment (IPE) (gloves, safety footwear...)
- Disconnect all lines affecting the valve and put up a notice notifying that work is being carried out on the valve
- Isolate the valve completely from the process
- Release process pressure
- Drain the fluid from the valve

Installation location:

- The installation location shall be chosen where representative measuring values are granted e.g after pumps good. Best location is always on straight piece of pipeline, never in elbows nor corners.
- When the sampler is installed immediately after a stock pump, it should be mounted on the side with regard to the pump.
- TP valves can be mounted on pipes DN100 to DN 800. Flange fitting (2) is shaped to pipe DN 150; for bigger or smaller sizes fillet welds are required to fill the gaps between flange fitting (2) and pipe hole.

Installation procedure:

The TP valve is supplied with a flange fitting (2).

1. Loose flange fitting (2) from the valve (fig 1) and remove the O-ring (8).
2. Drill a hole on the desired sample point into the pipe with diameter 43mm for DN25 valve or 58mm for DN40 valve. Use preferably a SS hole saw to get a perfect round cut-out and prepare it for welding (smooth edges).
3. Weld the flange fitting into the hole of the pipe so that the flange fitting is flush with the inner surface of the pipe. Make sure the angle is about 90 degr to the pipe and the discharge end of the sampler valve is looking down.

Welding instructions:

1. Insert the pipe fitting to the pipe hole and so that edges are flush to the inside surface of the pipe*.
2. Tack weld the fitting to the pipe and let it cool down.
3. Weld all the joint perimeter by TIG welding (welding rod AISI 316 diam 4 mm, inert gas Argon)
 - Weld thickness ~4 mm
 - Let welding fillets cool down
 - Apply a flux for cleaning

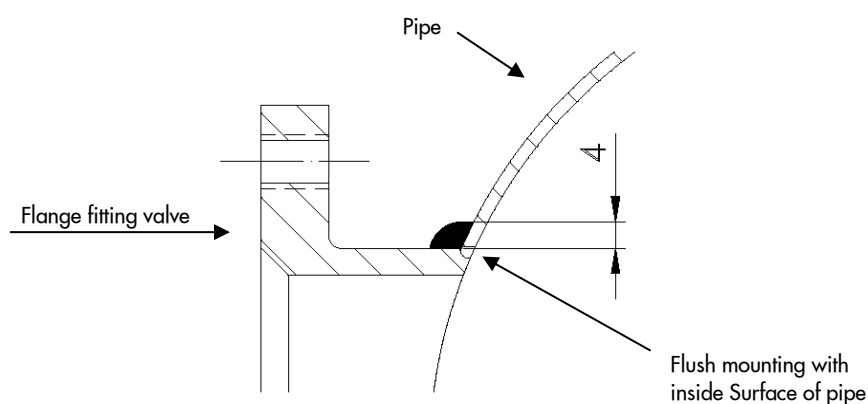

Note:

Welding and subsequent inspection are to be performed according to the applicable local regulations by specialists.

4. Fit the valve to the flange fitting (2) and do not forget to put the O-ring (8) back. (Fig.3)
5. Operate the valve (from the lever) with no flow in the pipeline to confirm there is no blockage for the stem movement. Sampling discharge hose is recommended.

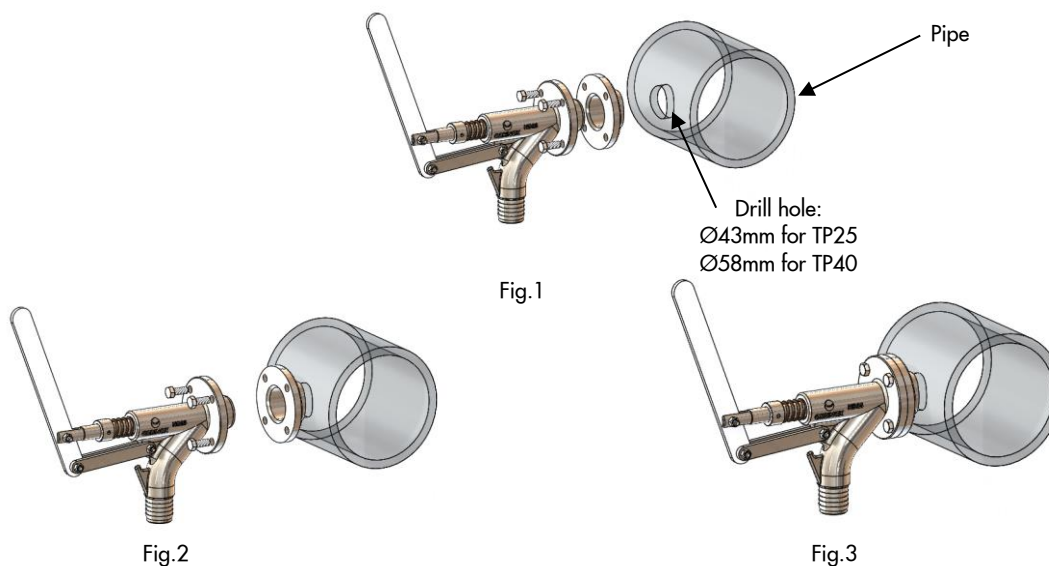

2. ACTUATORS

2.1. LEVER

These valves are commonly actuated by means of a lever. In order to operate, move the lever towards the opening or closing position. The closing assisted by means of a spring (11), which keeps the valve in the closed position.

2.2. PNEUMATIC

Pneumatic valves are usually supplied with single-acting actuators. Size of the actuator for each valve size has been designed for an air supply of 6 Kg/cm². The maximum allowable air supply is 10kg/cm².

It is essential for a good maintenance of the cylinder that air should be well dried, filtered and lubricated. Air quality shall fulfil the following requirements:

- ISO 8573-1 Grade 5:4:3 for regular process (ON / OFF services).
- ISO 8573-1 Grade 5:3:3 for regular process at low temperature (-20 °C).

It is recommended to actuate the cylinder 3-4 times before the start up, once it is installed in the pipeline.

3. MAINTENANCE

The valve must not undergo any modifications without a previous agreement with ORBINOX. ORBINOX shall not be liable for any damages that may arise due to the use of non original parts or components



To avoid personal injury or damage to property from the release of process fluid:

- Those in charge of handling and maintenance of the valve must be qualified and trained in valve operations.
- Use appropriate personal protection equipment (gloves, safety shoes, etc).
- Shut off all operating lines to the valve and place a warning sign.
- Isolate the valve completely from the process.
- Release process pressure.
- Drain the process fluid from the valve.

The only maintenance required is to change the 'O'-ring (9).

The life of this part will depend on the working conditions of the valve such as: pressure, temperature, abrasion, chemical action, number of operations, etc.

3.1. Seal (9) replacement:

1. Remove the valve from the pipeline.
2. Disconnect the lever (6) from the stem (4) by removing the bolt (12).
3. Remove the collar (3), adjustable pin (5) and spring (11) in order to remove the stem (4).
4. Clean the housing and replace the 'O'-ring (9).
5. Replace the spring (11) and the collar (3) holding it with the pin (5).
6. Fix the lever (6) to the stem (4).
7. Replace the valve in the line and test.

4. STORAGE

- For long storage periods keep the valves indoors in a safe and dry place and protect it from any impact and or vibrations
- Storing temperatures: -10°C to +40°C
- Valves must be stored in either full open or full closed position
- For any component installed in the valves, electric motors, solenoid valves, etc, please refer to their own instructions manuals

5. ENVIRONMENTAL CONSIDERATIONS

- The packaging is made from environmentally friendly materials. Dispose of the packaging through the available recycling channels
- The valve is designed and manufactured with materials that can be recycled by specialised recycling firms. Once the life of the product is expired, you have to consider a proper disposal of the product in order to prevent any negative impact on the environment and allows for the recycling of valuable commodities
- Please follow the local environmental rules in your country for proper disposal

6. PARTS LIST & DRAWINGS

6.1.- LEVER ACTUATOR

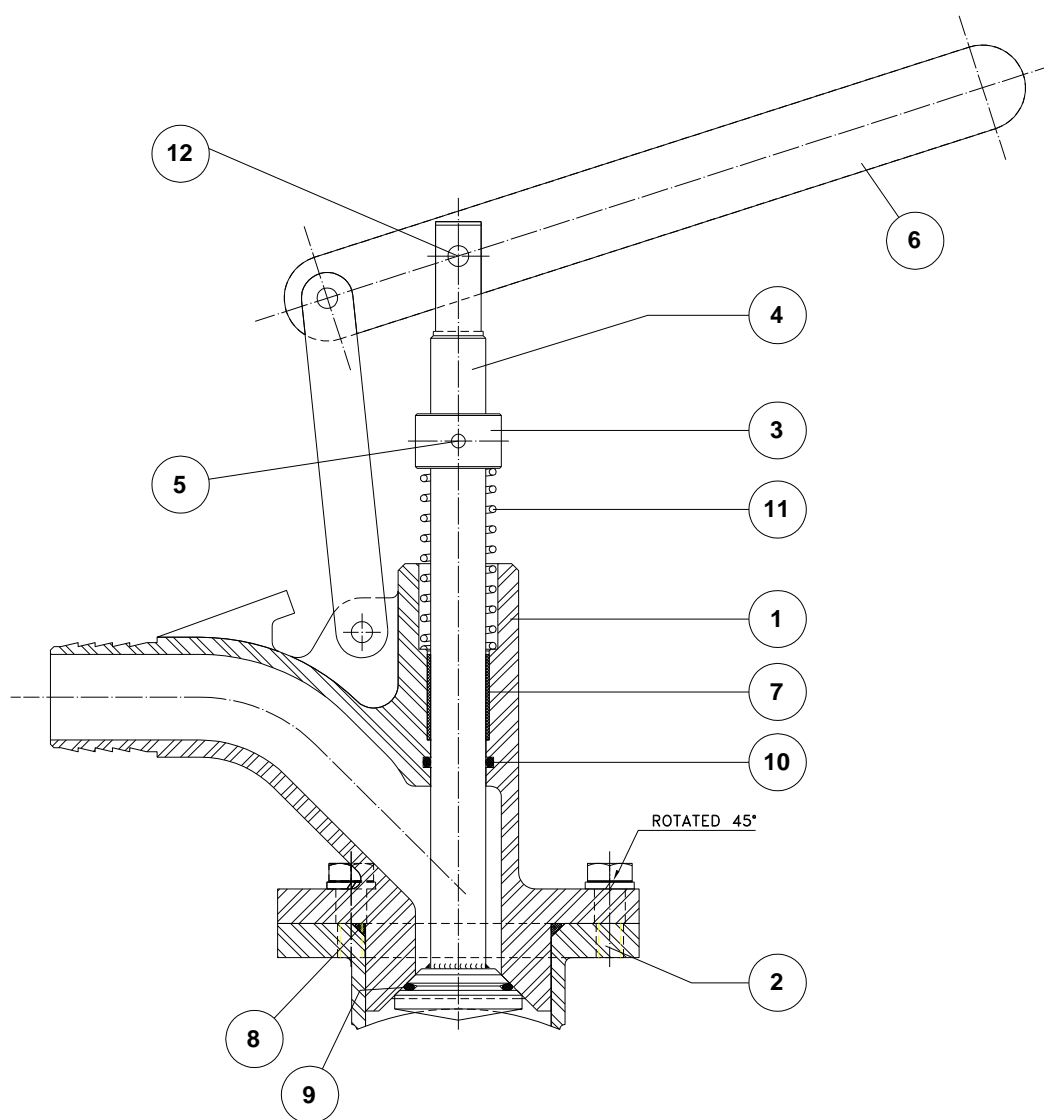

1. BODY	7. BEARING
2. FLANGE FITTING	8. O-RING
3. COLLAR	9. O-RING
4. STEM	10. O-RING
5. ADJUSTABLE PIN	11. SPRING
6. LEVER	12. BOLT

6. PARTS LIST & DRAWINGS

6.1.- PNEUMATIC ACTUATOR

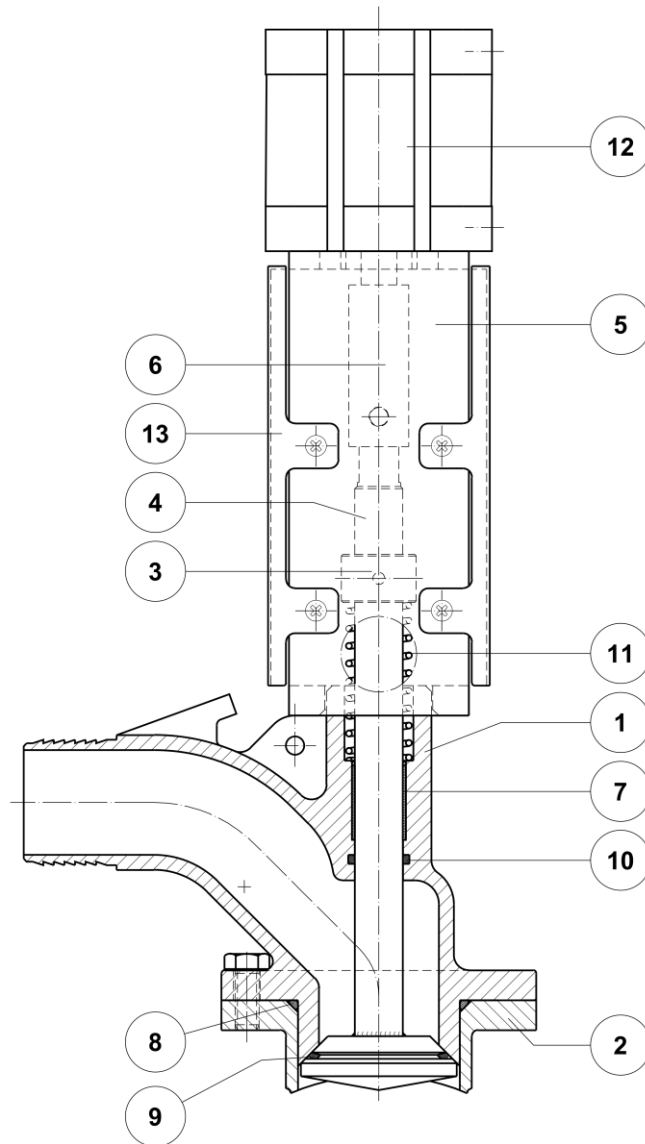

1. BODY	7. BEARING
2. FLANGE FITTING	8. O-RING
3. COLLAR	9. O-RING
4. STEM	10. O-RING
5. SUPPORT	11. SPRING
6. CLEVIS ROD	12. PNEUMATIC ACTUATOR